

SE TYPES

Dutchclamp® SE cable clamps are specially designed for short-circuit resistant fastening of single or multicore medium and high voltage cables. SE types are available in 7 models and suitable for cables with a diameter from 15 mm to 170 mm.

Dutchclamp® SE cable clamps are unique in their kind. The surfaces wherein the cables come to lie ensure perfect pressure distribution and maximum grip on the cables without sharp edges. In this way, there is no point load on the cables and the cables are not damaged. Dutchclamp SE cable clamps are manufactured from the highest quality, glass fibre reinforced polyamide and are therefore ideally suited for installations where very high short circuit forces may occur.

The unique raw material used in manufacturing these cable clamps, makes them resistant to corrosion, ozone, frost, heat, oil, acids, salts, aggressive chemicals, UV and nuclear radiation. There is no reduction in force within temperatures from -40° C to + 125° C. (225° C momentarily).

Dutchclamp® SE cable clamps have been tested by, among others, **UL (The Underwriters Laboratories U.S.A)**, the **Prof. Ir. Damstra laboratory (Eaton)** Volalab Grenoble (**Schneider**) and **SGS Brussels** in accordance with the **IEC 61914** international standard. All test reports are available upon request.

Dutchclamp® SE cable clamps are used worldwide and are therefore available from stock. They can also be supplied with appropriate fastening material.

Dutchclamp®

Cable clamps - Cable blocks

Certified in accordance with the IEC 61914 international safety standard

Dutchclamp has been developing and producing innovative cable clamps and cable blocks for installation of low, medium and high voltage cables since 1982. The clamps have been designed in close collaboration with major energy companies.

Dutchclamp is globally renowned for its quality, service and reliability. The Dutchclamp cable clamps and cable blocks are now being successfully used in more than 50 countries around the world.

The design

By way of the specific unique model, each type of cable clamp provides an exact fit for the required short-circuit resistant installation.

The raw material

Dutchclamp cable clamps are produced from high-quality virgin raw materials, with glass fibre reinforced polyamide as the main ingredient. The Dutchclamp cable clamps are self-extinguishing and halogen free.

Robustness

Owing to the unique design combined with the specific composition of the raw materials, these plastic cable clamps are among the strongest in the world. They are specially designed to withstand the enormous forces that occur during short-circuiting and have been tested by various laboratories.

Tests

The cable clamps have been tested by, among others, UL (The Underwriters Laboratories U.S.A), Prof. Ir. Damstra Laboratory (Eaton), Volta laboratory in Grenoble (Schneider), KEMA and SGS Brussels, in accordance with the IEC 61914 international standard.

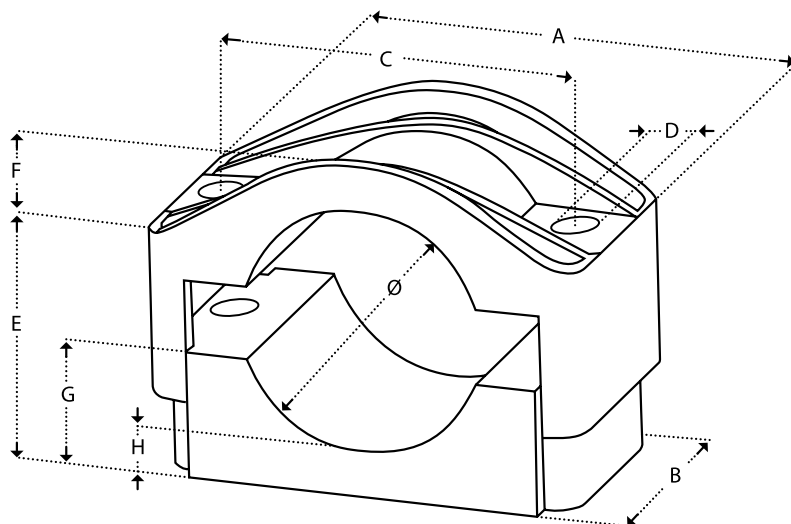

Dimensions in mm										N*
Typ	cable-Ø	A	B	C	D	E	F	G	H	
SE 15 - 26	15 - 26	77	45	50	10	26 - 42	4	17	8	8000
SE 26 - 38	26 - 38	92	60	60	12	33 - 49	7	18	7	12000
SE 36 - 52	36 - 52	105	60	75	12	39 - 55	15	23	8	12000
SE 50 - 75	50 - 75	126	60	95	12	46 - 71	22	30	9	12000
SE 75 - 100	75 - 100	200	80	150	15	70 - 95	32	45	10	20000
SE 100 - 135	100 - 135	225	85	175	15	85 - 120	43	58	10	20000
SE 135 - 170	135 - 170	260	90	210	15	133 - 169	62	90	28	20000

*Mechanical resistance to short-circuits in Newton

ADVANTAGES

- Resistant to short-circuit currents up to 202 kA.
- Resistant to oils, fats, aggressive chemicals, frost, heat, UV, ozone, salt, moisture, acids, and nuclear radiation.
- Self-extinguishing UL94, Halogen free.
- Temperature range from -40 °C to 125°C. (225°C momentarily).
- Coloured black.
- No magnetism / conductivity.
- Custom mounting available.
- Fastening materials can be supplied to size.
- No oxidation / corrosion.
- No sharp angles.
- Recyclable.
- Lifetime warranty.
- Very simple installation.
- Available worldwide.
- Certified in accordance with IEC 61914.

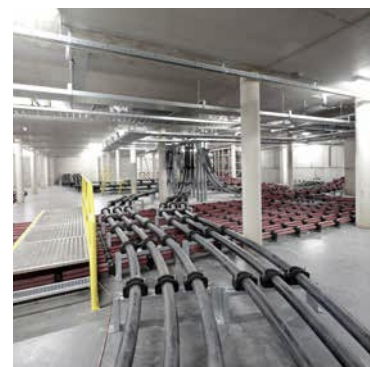



SEG TYPES

Dutchclamp® SEG cable clamps are specially designed for short-circuit resistant fastening of single or multicore medium and high voltage cables. SEG TYPES are available in 2 models and suitable for cables with a diameter from 26 mm to 50 mm (SEG 26-50) and 50 mm to 80 mm (SEG 50-80).

Dutchclamp® SEG cable clamps are unique in their kind. The surfaces wherein the cables come to lie ensure perfect pressure distribution and maximum grip on the cables without sharp edges. In this way, there is no point load on the cables and the cables are not damaged. SEG cable clamps are stackable and may also be fastened by means of the extra centre hole.

Dutchclamp® SEG cable clamps are manufactured from the highest quality glass fibre reinforced polyamide and are therefore ideally suited for installations where high short circuit forces may occur.

The unique raw material used in manufacturing these cable clamps, makes them resistant to corrosion, ozone, frost, heat, oil, acids, salts, aggressive chemicals, UV and nuclear radiation. There is no reduction in force within temperatures from -40° C to + 120° C.

Dutchclamp® SEG cable clamps have been tested by **SGS Brussels** and the **VoltaLab** in Grenoble (**Schneider**) in accordance with the **IEC 61914** international standard.

Dutchclamp® SEG cable clamps are used worldwide and are therefore available from stock. They can also be supplied with appropriate fastening material.

Dutchclamp®

Cable clamps - Cable blocks

Certified in accordance with the IEC 61914 international safety standard

Dutchclamp has been developing and producing innovative cable clamps and cable blocks for installation of low, medium and high voltage cables since 1982. The clamps have been designed in close collaboration with major energy companies.

Dutchclamp is globally renowned for its quality, service and reliability. The Dutchclamp cable clamps and cable blocks are now being successfully used in more than 50 countries around the world.

The design

By way of the specific unique model, each type of cable clamp provides an exact fit for the required short-circuit resistant installation.

The raw material

Dutchclamp cable clamps are produced from high-quality virgin raw materials, with glass fibre reinforced polyamide as the main ingredient. The Dutchclamp cable clamps are self-extinguishing and halogen free.

Robustness

Owing to the unique design combined with the specific composition of the raw materials, these plastic cable clamps are among the strongest in the world. They are specially designed to withstand the enormous forces that occur during short-circuiting and have been tested by various laboratories.

Tests

The cable clamps have been tested by, among others, UL (The Underwriters Laboratories U.S.A), Prof. Ir. Damstra Laboratory (Eaton), Volta laboratory in Grenoble (Schneider), KEMA and SGS Brussels, in accordance with the IEC 61914 international standard.

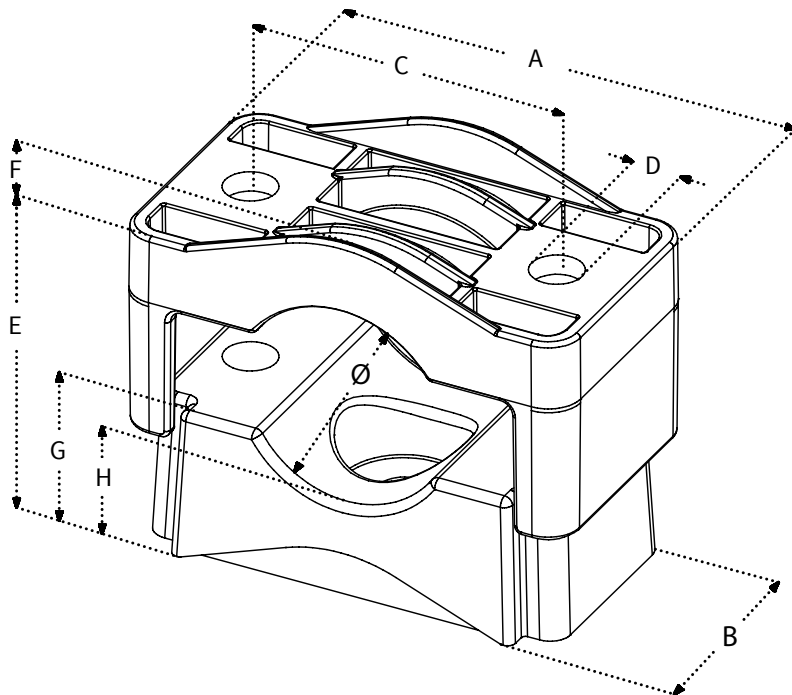

Dimensions in mm										N*
Typ	cable-ø	A	B	C	D	E	F	G	H	
SEG 26 - 50	26 - 51	111	60	76	12,5	55 - 80	12	36	24	15000
SEG 50 - 80	50 - 81	135	60	100	12,5	78 - 108	16	47	23	15000

*Mechanical resistance to short-circuits in Newton

ADVANTAGES

- Resistant to oils, fats, aggressive chemicals, frost, heat, UV, ozone, salt, moisture, acids, and nuclear radiation.
- Uniquely stackable
- Provided with an extra centre hole for mounting with 1 bolt.
- Self-extinguishing UL94, Halogen free.
- Temperature range from -40 °C to 120°C. (225°C) momentarily.
- Coloured black.
- No magnetism / conductivity.
- Custom mounting available.
- Fastening materials can be supplied to size.
- No oxidation / corrosion.
- No sharp angles.
- Recyclable.
- Lifetime warranty.
- Very simple installation.
- Available worldwide.



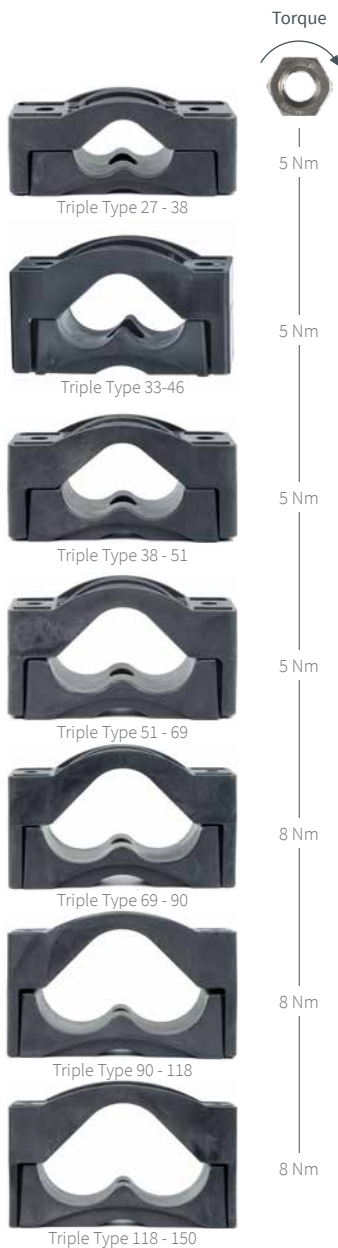

TRIPLE TYPES

Dutchclamp® Triple cable clamps are specially designed for short-circuit resistant fastening of cables in trefoil applications. Triple types are available in 7 models and suitable for cables with a diameter from 27 mm to 150 mm.

Dutchclamp® Triple cable clamps are unique in their kind. The surfaces wherein the cables come to lie ensure perfect pressure distribution and maximum grip on the cables without sharp edges. In this way, there is no point load on the cables and the cables are not damaged. The Triple cable clamps are also stackable. Dutchclamp® Triple cable clamps are manufactured from the highest quality glass fibre reinforced polyamide and are therefore ideally suited for installations where high short circuit forces may occur.

The unique raw material used in manufacturing these cable clamps, makes them resistant to corrosion, ozone, frost, heat, oil, acids, salts, aggressive chemicals, UV and nuclear radiation. There is no reduction in force within temperatures from -40° C to + 125° C (momentarily up to 225° C).

Dutchclamp® Triple cable clamps have been tested by, among others, **UL (The Underwriters Laboratories U.S.A)**, **Voltalab** in Grenoble (**Schneider**), the **Prof. Ir. Damstra laboratory (Eaton) KEMA** and **SGS Brussels** in accordance with the **IEC 61914** international standard. (All test reports are available upon request).

Dutchclamp® Triple cable clamps are used worldwide and are therefore available from stock. They can also be supplied with appropriate fastening material.

Dutchclamp®

Cable clamps - Cable blocks

Certified in accordance with the IEC 61914 international safety standard

Dutchclamp has been developing and producing innovative cable clamps and cable blocks for installation of low, medium and high voltage cables since 1982. The clamps have been designed in close collaboration with major energy companies.

Dutchclamp is globally renowned for its quality, service and reliability. The Dutchclamp cable clamps and cable blocks are now being successfully used in more than 50 countries around the world.

The design

By way of the specific unique model, each type of cable clamp provides an exact fit for the required short-circuit resistant installation.

The raw material

Dutchclamp cable clamps are produced from high-quality virgin raw materials, with glass fibre reinforced polyamide as the main ingredient. The Dutchclamp cable clamps are self-extinguishing and halogen free.

Robustness

Owing to the unique design combined with the specific composition of the raw materials, these plastic cable clamps are among the strongest in the world. They are specially designed to withstand the enormous forces that occur during short circuiting and have been tested by various laboratories.

Tests

The cable clamps have been tested by, among others, UL (The Underwriters Laboratories U.S.A), Prof. Ir. Damstra Laboratory (Eaton), Volta laboratory in Grenoble (Schneider), KEMA and SGS Brussels, in accordance with the IEC 61914 international standard.

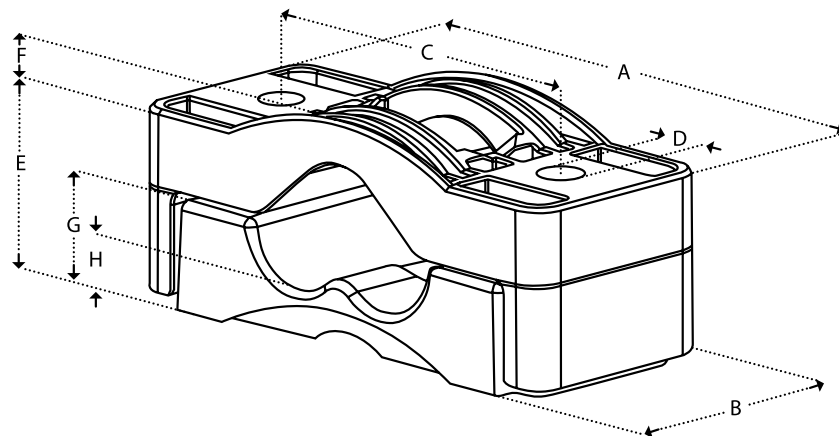

Dimensions in mm										N*
Typ	cabl-e-ø	A	B	C	D	E	F	G	H	
TRIPLE 27 - 38	3x 27 - 38	180	75	125	15	63 - 90	12	35	16.5	25000
TRIPLE 33 - 46	3x 33 - 46	154	70	115	13	76 - 105	15	40	19	17000
TRIPLE 38 - 51	3x 38 - 51	195	80	145	15	84 - 115	16	45	20	25000
TRIPLE 51 - 69	3x 51 - 69	220	85	170	15	109 - 150	21	58	26	25000
TRIPLE 69 - 90	3x 69 - 90	252	90	215	15	134 - 185	29	72	30	27500
TRIPLE 90 - 118	3x 90 - 118	321	100	270	15	180 - 250	27	89	33	27500
TRIPLE 118 - 150	3x 118 - 150	400	110	340	15	211 - 310	37	110	75	27500

*Mechanical resistance to short-circuits in Newton

ADVANTAGES

- Resistant to short-circuit currents / forces up to 150 kA.
- Resistant to oils, fats, aggressive chemicals, frost, heat, UV, ozone, salt, moisture, acids, and nuclear radiation.
- Self-extinguishing UL94, Halogen free.
- Temperature range from -40 °C to 125°C. (225°C) momentarily.
- Coloured black.
- No magnetism / conductivity.
- Custom mounting available.
- Fastening materials can be supplied to size.
- No oxidation / corrosion.
- No sharp angles.
- Recyclable.
- Lifetime warranty.
- Very simple installation.
- Available worldwide.
- Stackable.
- Certified in accordance with IEC 61914





IM TYPES

Dutchclamp® IM cable blocks are specially designed for short-circuit resistant and safe fastening of single or multicore medium and high voltage cables. IM types are available in 4 models and suitable for cables with a diameter from 12 mm to 32 mm and 32 mm to 48 mm. They can be coupled to each other laterally by means of a dovetail joint and are stackable.

Dutchclamp® IM cable blocks are unique in their kind. The surfaces wherein the cables come to lie ensure perfect pressure distribution and maximum grip on the cables without sharp edges. In this way, there is no point load on the cables and the cables are not damaged. Dutchclamp IM cable blocks are manufactured from the highest quality glass fibre reinforced polyamide and are therefore ideally suited for installations where very high short circuit forces may occur.

The unique raw material used in manufacturing these cable clamps, makes them resistant to corrosion, ozone, frost, heat, oil, acids, salts, aggressive chemicals, UV and nuclear radiation. There is no reduction in force within temperatures from -40° C to + 125° C. (momentarily 225° C).

Dutchclamp® IM cable blocks have been tested by, among others, UL (The Underwriters Laboratories U.S.A), the Prof. Ir. Damstra laboratory (Eaton) Voltalab Grenoble (Schneider) and SGS Brussels in accordance with the IEC 61914 international standard.

Dutchclamp® IM cable blocks are used worldwide and are therefore available from stock. They can also be supplied with appropriate fastening material.

Dutchclamp®

Cable clamps - Cable blocks

Certified in accordance with the IEC 61914 international safety standard

Dutchclamp has been developing and producing innovative cable clamps and cable blocks for installation of low, medium and high voltage cables since 1982. The clamps have been designed in close collaboration with major energy companies. Dutchclamp is globally renowned for its quality, service and reliability. The Dutchclamp cable clamps and cable blocks are now being successfully used in more than 50 countries around the world.

The design

By way of the specific unique model, each type of cable clamp provides an exact fit for the required short-circuit resistant installation.

The raw material

Dutchclamp cable clamps are produced from high-quality virgin raw materials, with glass fibre reinforced polyamide as the main ingredient. The Dutchclamp cable clamps are self-extinguishing and halogen free.

Robustness

Owing to the unique design combined with the specific composition of the raw materials, these plastic cable clamps are among the strongest in the world. They are specially designed to withstand the enormous forces that occur during short circuiting and have been tested by various laboratories.

Tests

The cable clamps have been tested by, among others, UL (The Underwriters Laboratories U.S.A), Prof. Ir. Damstra Laboratory (Eaton), Volta laboratory in Grenoble (Schneider), KEMA and SGS Brussels, in accordance with the IEC 61914 international standard.

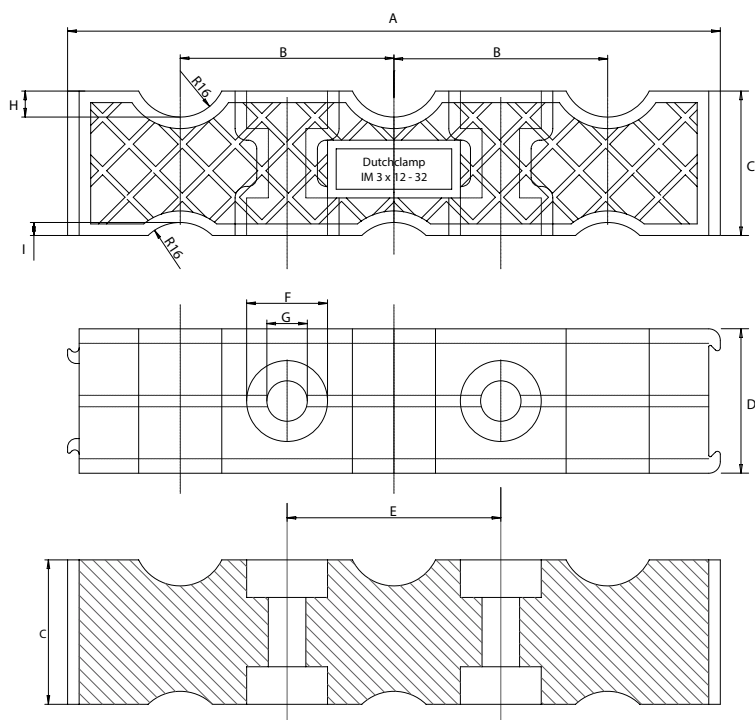

Typ	Dimensions in mm									N*
	A	B	C	D	E	F	G	H	I	
IM 3 x 12-32	226	74	50	50	74	28	14	9	4,5	69500
IM 4 x 12-32	280	74	50	50	147	28	14	9	4,5	69500
IM 4 x 32-48	345	85	65	50	170	28	14	18	10	69500
IM 6 x 32-48	400	58	65	50	254	28	14	18	10	69500

*Mechanical resistance to short-circuits in Newton

ADVANTAGES

- Resistant to gigantic short-circuit currents / forces.
- Resistant to oils, fats, aggressive chemicals, frost, heat, UV, ozone, salt, moisture, acids, and nuclear radiation.
- Self-extinguishing UL94, Halogen free.
- Temperature range from -40 °C to 125°C. (225°C momentarily)
- Coloured black.
- No magnetism / conductivity.
- Custom mounting available.
- Fastening materials can be supplied to size.
- No oxidation / corrosion.
- No sharp angles.
- Recyclable
- Lifetime warranty
- Very simple installation.
- Available worldwide.
- Stackable
- Certified in accordance with IEC 61914

